

Application Note: R320 Two Set Point Control

Application:

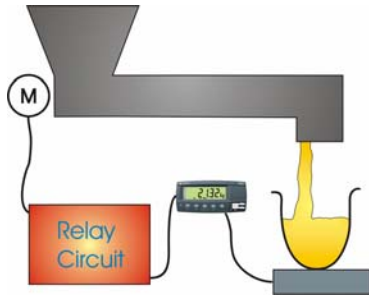

A weighing machine is to be used in a coarse filling weighing system using an R320 indicator. Set points working into a relay circuit do the motor speed control and a remote tare function is used with the start.

The final target weight of the bag is 25kg. The filling machine is a two speed screw auger which uses basic relay logic for its control circuitry.

Two Set Point Outputs - are used to control the filling speed change over point and the final cut off weight. The filling auger starts at hi-speed until set point one is reached where the speed slows until set point two is reached and filling is stopped.

Set points are used as Over or Under depends on the relay circuit logic, in this example:

Set Point 1: Motor Speed Control - controls the relays dictating the motor speed – set to Over 20kg – when it is activate the voltage input on the motor reduces, reducing the fill speed for when the weight is Over 20kg.

Set Point 2: Motor Control Interlock - controls the relays that create an interlock on the motor control – set to Under 25kg – when it is active the motor will operate.

Remote TARE - To allow for varying bag weights (tare weight) the remote TARE function is used to maintain a true zero starting point. When the operator pushes the start button on the filling unit a relay closes and activates the tare input.

Programmable function key - can be assign to set point to allow the operator to view and edit the set point targets.

Components:

Rear Boot Options



R320
R320-K302-A



Desk Mount
M3001

Mounting Options



Swivel Mount
M3002



R323
R323-K302 + M3010
Alternative Indicator



Waterproof Rear Boot
M3003



Stand
M3007

Operation:

Set Point 1: controls the relays dictating the motor speed – it is set to Over 20kg – when it is activate voltage input on the motor reduces, reducing the fill speed for when the weight is Over 20kg.

Set Point 2: controls the relays that create an interlock on the motor control – it is set to Under 25kg – when it is active the motor will operate.

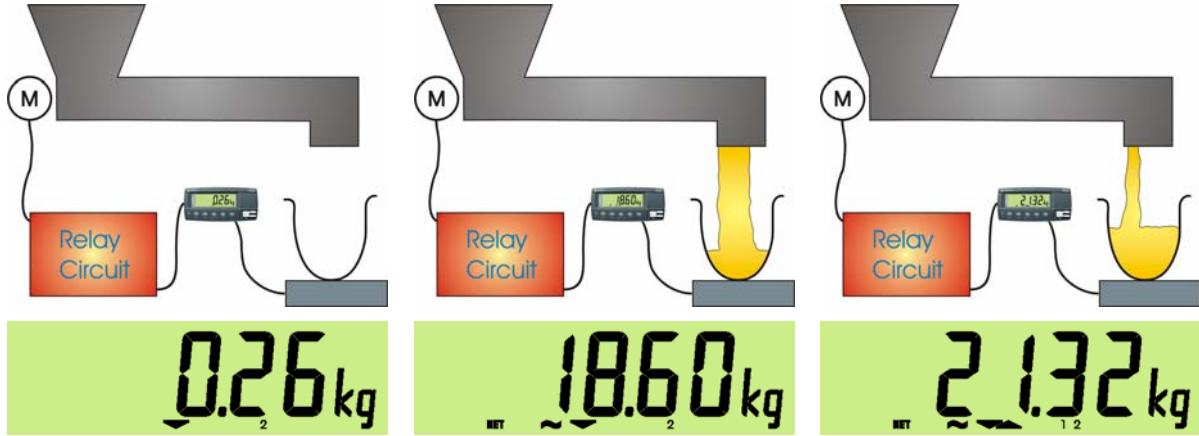

1. The empty bag is placed on the scale. The operator presses the start button when ready and the bag weight is automatically tared off.

2. The auger operates at hi-speed up to 20kg filling the bag.

3. Once 20kg is reach, SP1 also activates to reduce to a slow speed fill.

SP2 (Under set point 25kg) is active while the weight is less than 25kg.

(SP1 active switches a relay on the voltage input into to motor to reduce the speed.)

SP1 (Over set point 20kg) is not active.

SP2 (Under set point 25kg) remains active while the weight is less than 25kg.

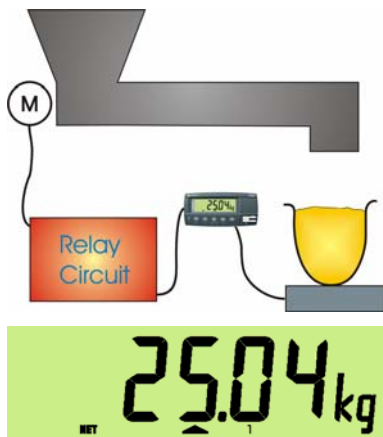

4. When the weight reaches 25kg the filling is stopped. (SP2 switches off which releases the latch on the relay for the motor)

The bag is removed and filling will only restart when the Start button is pushed.

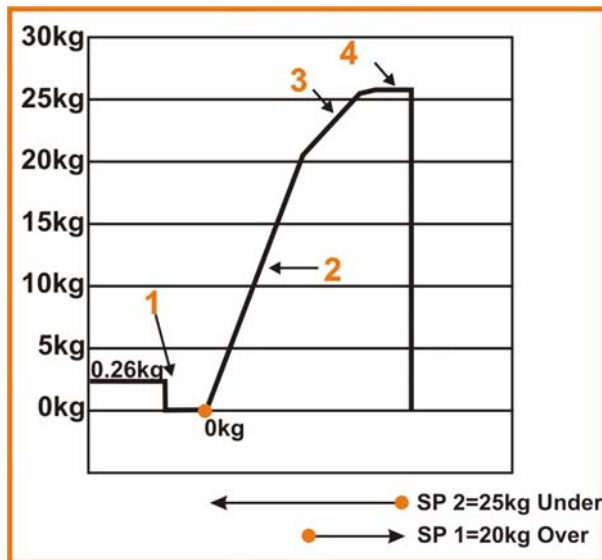

Configuration:

FULL SETUP

BUILD	setup as required
OPTION	setup as required
CAL	setup as required
_SPEC	
_SAFE.PC:	as required
_FULL.PC:	as required
_KEY.LOC:	as required
_KEY.FN:	If operator target value access is required then set to _SET.PT_ else set as required for other available functions. Refer to manual for list.
_AUT.OFF:	as required
_B.LIGHT:	as required
_REM.FN:	If a remote Tare is required then set to _KEY2_ (TARE) else set as required. Note for the REM.FN to work SERIAL:TYPE must be set to AUTO. Refer to manual for details.
_BAT.VLT:	as required
_SERIAL	
_TYPE:	AUTO (for the remote input to be enabled)
_FORMAT:	as required
_BAUD:	as required
_BITS:	as required
_ADDRES:	as required
_RST.CON:	as required
_SET.PTS	
_SETPT.1:	OVER
_SRC.1:	NET
_TARG.1:	0020.00 kg (can be altered by operator if _KEY.FN:SET.PTS)
_SETPT.2:	UNDER
_SRC.1:	NET
_TARG.2:	0025.00 kg (can be altered by operator if _KEY.FN:SET.PTS)
CLOC	setup as required
TEST	
FACTRY	
END	

Remote Input:

The indicator requires a voltage free contact between TXD and RXD to enable the remote input (i.e. SPEC:REM.FN). The SERIAL:TYPE option must be set to AUTO.

Note: The remote input will not function when in setup or when using the OPTO-LINK.

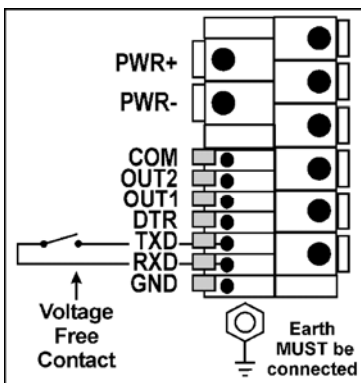

WARNING
 The remote input is a voltage free contact (Eg. button, mechanical relay).
 Connection of any active circuitry may damage the instrument.

Outputs:

The output drivers for the instrument are isolated transistor drives that are capable of driving up to a total of 300mA. This configuration allows for the direct connection of the instrument outputs to most types of PLC. The voltage applied to the COM terminal appears on the output lines (i.e. OUT1 and OUT2) when the outputs are active (eg. to connect to a PLC connect +24V to the common terminal). The outputs can then be connected directly to PLC inputs so when activated are active the PLC will see a 22V signal (approx. - the exact switch loss will depend on loading of the output).

To drive external loads (eg. relays), connect the relay coil positive supply to the output common and the output line directly to one side of the relay coil. Connect the other end of the relay coil to the negative supply.

It is recommended that flyback diodes or transient suppressors be fitted across relay coils to limit switching noise.

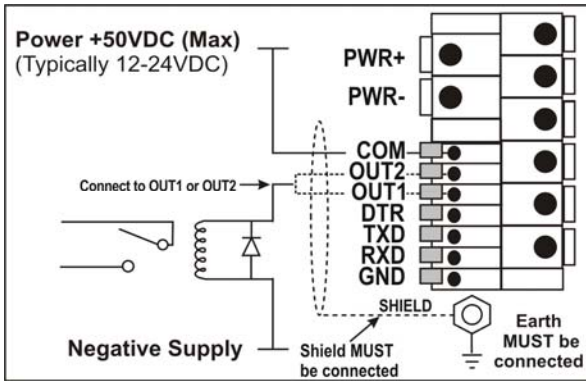

Figure 9: Instrument Outputs to Drive Relays

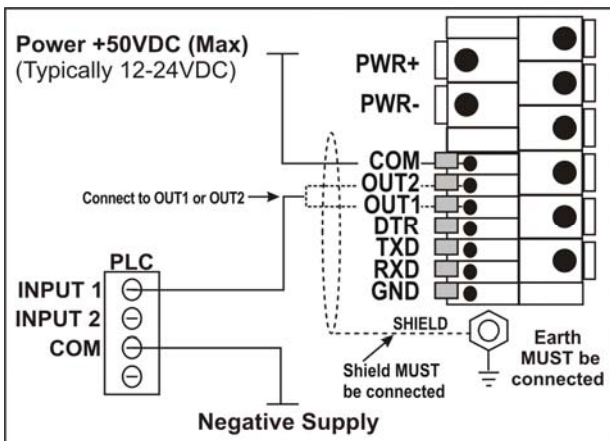

Figure 10: Instrument Outputs to Drive PLC

Relay Circuit

The diagram below illustrates the relay circuitry using an M4901 relay board.

